



HODARA®
ART DESIGNER



Hodaraartdesigner

Hodara Art Designer è un laboratorio d'intuizioni, di sensazioni, di idee che si trasformano in oggetti. Un'alchimia basata sul gusto per l'essenzialità, un innato istinto per l'unicità.

La ricerca della bellezza attraverso l'essenziale, dell'unicità dell'essere che si manifesta nelle scelte. Un trait d'union che unisce, in un rapporto sottile, l'art designer, il mastro artigiano e la selezione esclusiva delle materie prime.

Intensità del tratto che prende forma nel plexiglass, nel rovere, nella pelle pieno fiore, nel rame anticato, nell'erba palustre, negli abbinamenti insoliti, arditi, tecnicamente impossibili. Infinite possibilità, per imprimere nella materia la traccia fisica delle emozioni.

Trasparenze e riflessi. Vuoti e pieni in equilibrio. La curva come filo conduttore, alla ricerca dell'essenziale.

Hodara Art Designer is a laboratory of intuition, sensations and ideas that transform into objects. An alchemy based on a taste for simplicity, an instinct for uniqueness.

The pursuit of beauty through the essential uniqueness of being which manifests itself in choices. A liaison that joins in a subtle relationship the art designer, the master craftsman and the exclusive selection of raw materials.

The intensity of a line that takes shape in plexiglass, in oak, in creamy leather, in antiqued copper, in marsh grass, in unusual, daring, technically impossible combinations. Endless possibilities, to imprint matter with the physical trace of emotions.

Transparencies and reflections. A balance of emptiness and fullness. The curve as the main theme, the search for the essential.

VittorioHodara

La visione di Vittorio Hodara nasce dalla cultura per una naturale eleganza, che si esprime in dettagli eccellenti, in materiali ricercati, in linee raffinate. Un'eleganza che riecheggia nel "less is more" di Mies Van de Rohe.

Un'attitudine per la ricerca, per l'esplorazione. Uno sguardo curioso verso quello che lo circonda, il bisogno di unicità. E' così che scaturisce l'esigenza di creare oggetti con meno linee, che procurino sensazioni di leggerezza, di benessere, che vivano in un presente senza tempo, liberi dalle mode.

"Ad un certo punto della mia vita - racconta Vittorio Hodara - mi sono regalato un sogno che cullavo da anni: quello di creare gli oggetti che mi sarebbe piaciuto trovare in uno spazio ideale. Così è nata la mia collezione di interior design. Basata sulla ricerca della forma, basata sul togliere e non sull'aggiungere, puntando ad una qualità senza compromessi, una delle cose che hanno reso il "made in Italy" famoso nel mondo."

Vittorio Hodara's vision stems from the culture that favors natural elegance, which is expressed in excellent details, unusual materials, refined lines. An elegance that echoes the "less is more" approach of Mies Van de Rohe.

An aptitude for research, for exploration. A curious look at what surrounds him, the need for uniqueness. And thus arises the need to create objects with fewer lines, providing sensations of lightness, of well-being, that live in a timeless present, unfettered by fashion.

"At a certain point in my life," Vittorio Hodara explains, "I realized a dream I had been cradling for years: to create objects that I'd want to find in ideal spaces. This is how my interior design collection was created. Based on the research of form, based on taking away rather than adding on, and aimed at quality without compromise, one of the things that has made "Made in Italy" famous the world over.



handcraft



Libertà creativa è regola d'arte.

Intelligenza della mano, puntigliosa passione,
secolare esperienza.

La via più bella è quella più ardua.

Senza eccezioni, senza compromessi, 100% made in Italy.

Creative freedom is the secret.

Intelligent craftsmanship, determination and passion,
plus many years of experience.

The most rewarding life is a tough life.

No exceptions, no compromises, 100% made in Italy.

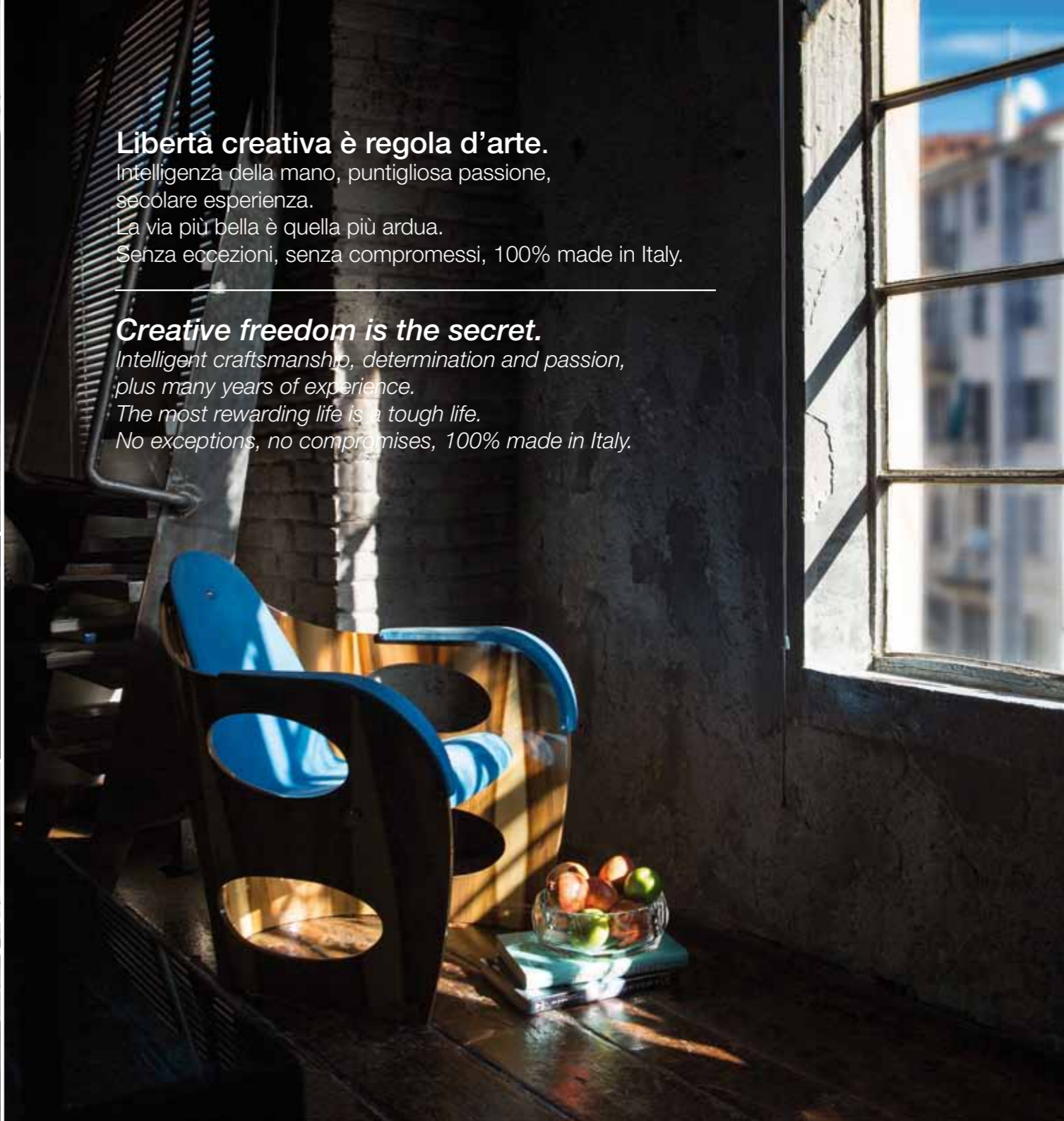



HODARA®
ART DESIGNER

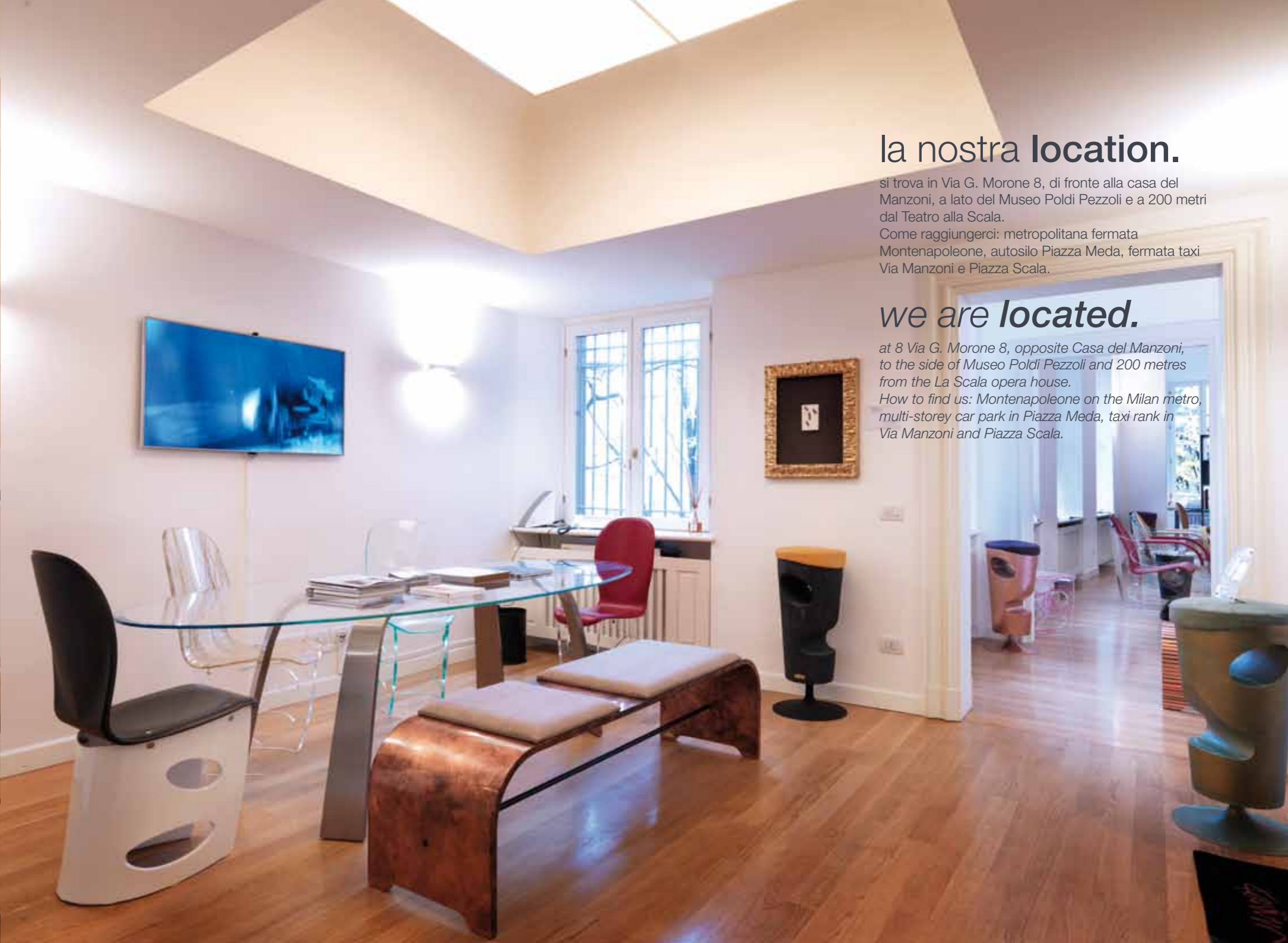

la nostra location.

si trova in Via G. Morone 8, di fronte alla casa del Manzoni, a lato del Museo Poldi Pezzoli e a 200 metri dal Teatro alla Scala.
Come raggiungerci: metropolitana fermata Montenapoleone, autosilo Piazza Meda, fermata taxi Via Manzoni e Piazza Scala.

we are located.

at 8 Via G. Morone 8, opposite Casa del Manzoni, to the side of Museo Poldi Pezzoli and 200 metres from the La Scala opera house.
How to find us: Montenapoleone on the Milan metro, multi-storey car park in Piazza Meda, taxi rank in Via Manzoni and Piazza Scala.



A NEW
WAY OF
LIVING

living

A NEW
WAY OF
LIVING



Collezione "Lovale"

Divano, poltrona, pouf e una poltroncina da tavolo, nel segno della sinuosità dell'ovale. Leggera alla vista ma solida e compatta al tocco, la collezione presenta dettagli raffinati e cura artigiana anche negli elementi strutturali.

Lo scafo in legno riporta quasi al mondo dei maestri d'ascia, i rivestimenti sono sartoriali e le cuciture si fanno preziose nel doppio passo ravvicinato.

"Lovale" Collection

Sofa, armchair, hassock and dining room chair embodying the sinuousness of the oval. Visually light but solid and compact to the touch, the collection presents refined details and fine craftsmanship right down to the structural elements. The wooden frame almost takes one back to the times of the master boatbuilders; the upholstery fabrics could be those of a tailor, while the seams are enhanced by tight double-stitching.

workspace

A NEW
WAY OF
LIVING



Workspace

Lo spazio di lavoro si trasforma in un ambiente comodo e raffinato. La scrivania "Spaziomio" si abbina all'eclettismo delle sedute, disegnando un ambiente funzionale ed esclusivo.

The workspace become an elegant and comfortable environment. The "Spaziomio" desk is a perfect mate for the eclectic seating, creating a functional and exclusive ambiance.

studio

A NEW
WAY OF
LIVING



Studio

Una combinazione di elementi di design che diviene "luogo", di incontro, di sosta, di pensiero. La sorprendente comodità di sedute essenziali, giocate sulla sinuosità della curva, su materiali di pregio, confezionati con cura artigianale.

A combination of design elements that become "places" for encounters, pauses and contemplation.

The surprising comfort of simple seating, played upon by the sinuousness of the curve, by the distinctive materials, put together with care and masterful craftsmanship.



meeting

A NEW
WAY OF
LIVING

Meeting

Eterea e solida, trasparente e materica, questa l'alchimia dell'isola creata dal tavolo "Spicchio" e dalle sedute della collezione Sinuosa. "Meeting" è luogo di incontro, ma anche di raffinato convivio.

*Ethereal and solid,
transparent and expressive:
this is the alchemy that creates the
island that is the "Spicchio" table
and the Sinuosa seating collection.
"Meeting" is a place not only to get
together, but to BE together
in elegance.*



day

A NEW
WAY OF
LIVING



Day

Le luce del giorno colora lo spazio, enfatizza i riflessi del tavolo Elica, attraverso la trasparenza delle sedute. Poltrone e tavolini popolano la zona living, delimitando aree di raffinata personalità.

Daylight gives color to space, emphasizing the reflections in the Elica table seen through the transparency of the chairs. Armchairs and small tables populate the living room, circumscribing areas of refined personality.

suite

A NEW
WAY OF
LIVING



Suite

La camera calda e raffinata, si ispira all'esclusività della "suite". La collezione personalizza gli oggetti di uso comune, così il comodino "Accanto" diviene rigorosa icona grafica, contrapposta alla morbidezza della testiera e delle sedute "Lovale".

The room is warm and sophisticated, inspired by the exclusiveness of a "suite". The collection personalizes everyday objects, making the "Accanto" night table a graphic icon in contrast to the softness of the headboard and "Lovale" seating.

lovalesofà

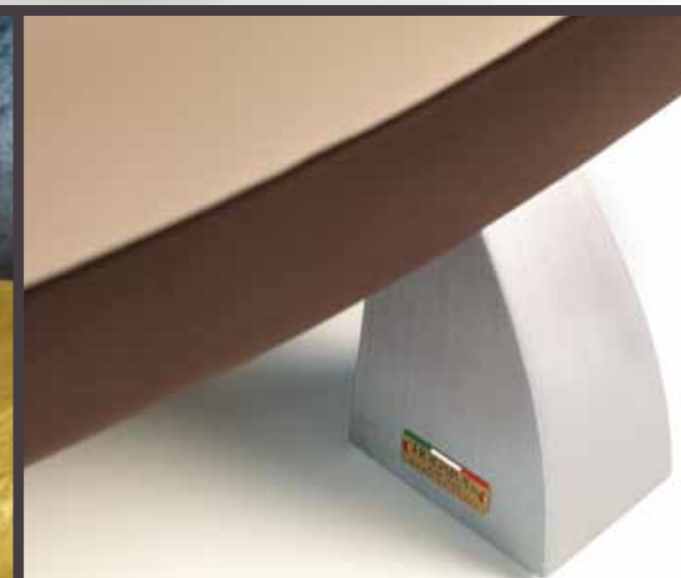

VH15_014 | lovalesofà

**La sinuosità dell'ovale,
l'ellisse disegna lo spazio.**
La simmetria come eleganza naturale.

**The sinuousness of the oval,
the ellipse defines space.**
Symmetry as natural elegance.

Frame/Seating Finishes

Fabric: cotton - velour
elasticized fabric
fake fur
Leather: full grain ("pieno fiore") - nabuk
Special finishes

Legs Finishes

Brushed steel effect
Oxidized metal effect
Lacquered:
gloss - semi-gloss - flat
Wood: natural flat
gloss finish oak
bleached oak
Flat wenge effect
gloss - semi-gloss gold
Special finishes

Finitura Struttura/Seduta

Tessuto: cotone - velluto
tessuto elastico
pelliccia sintetica
Pelle: pieno fiore - nabuk
finiture speciali

Finitura Piedini

Effetto acciaio satinato
Effetto metallo ossidato
Laccato:
lucido - semilucido - opaco
Legno: naturale opaco
rovere tinto lucido
rovere sbiancato
Effetto wengé opaco
lucido - oro semilucido
Finiture speciali

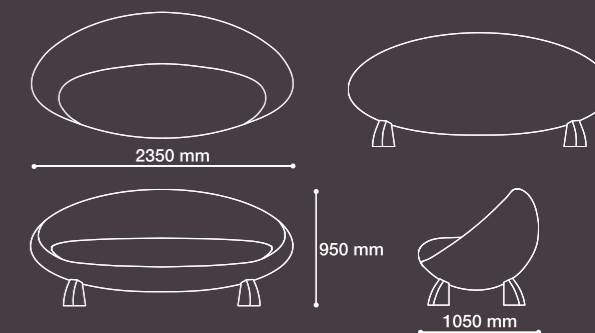

elicatavolino

VH15_015 | elicatavolino

Materia e forma si inseguono, si fondono.
Come un'icona dell'eterno movimento.

**Substance and form run
after each other, then meld.**
Like an icon of eternal movement.

Table Base

Varnished: glossy - semi-glossy - matt
metallic - antique
Wood: oak - walnut - wenge
zircote - ebony
Special finishes

Surface

Varnished: glossy - semi-glossy - matt
metallic - antique
Wood: oak - walnut - wenge
zircote - ebony
Special finishes

Helicoidal inserts in the surface

Electroplating: polished chrome
satin - copper - brass
Oxidised metal effect
Varnished: glossy - semi-glossy
matt - metallic - antique
Treatment with takemakite® and cinnabar
Calacatta Marble
Special finishes

Basamento tavolo

Laccato: lucido - semilucido - opaco
metallizzato - anticato
Legno: rovere - noce - wengé
zircote - ebano
Finiture speciali

Piano

Laccato: lucido - semilucido - opaco
metallizzato - anticato
Legno: rovere - noce - wengé
zircote - ebano
Finiture speciali

Inserti elicoidali nel piano

Bagno Galvanico: cromato lucido
satinato - ramato - ottonato
Effetto metallo ossidato
Laccato: lucido - semilucido - opaco
metallizzato - anticato
Trattamento con takemakite® e cinabro
Marmo Calacatta
Finiture speciali



lovalepoltrona



VH15_016 | lovalepoltrona

Archetipo dell'eterno ciclo della vita.

Artigianale anche nel profondo.
Lo scafo in legno riporta all'arte dei maestri d'ascia.

The archetype of the eternal cycle of life.

Deep-down craftsmanship.
The wooden frame recalls the master boatbuilders.

Frame/Seating Finishes

Fabric: cotton - velour
elasticized fabric
fake fur
Leather: full grain ("pieno fiore") - nabuk
Special finishes

Legs Finishes

Brushed steel effect
Oxidized metal effect
Lacquered:
gloss - semi-gloss - flat
Wood: natural flat
gloss finish oak
bleached oak
Flat wenge effect
gloss - semi-gloss gold
Special finishes

Finitura Struttura/Seduta

Tessuto: cotone - velluto
tessuto elastico
pelliccia sintetica
Pelle: pieno fiore - nabuk
finiture speciali

Finitura Piedini

Effetto acciaio satinato
Effetto metallo ossidato
Laccato:
lucido - semilucido - opaco
Legno: naturale opaco
rovere tinto lucido
rovere sbiancato
Effetto wengè opaco
lucido - oro semilucido
Finiture speciali

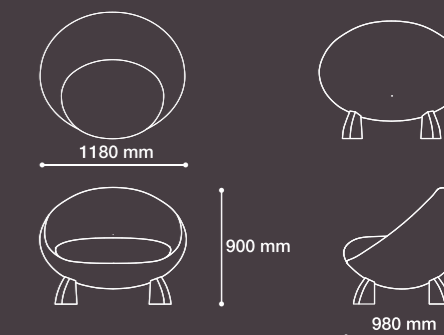

lovalepouf



VH15_017 | lovalepouf

La curva come modello della natura.
Rigorosa essenza di bellezza.

The curve as a model of nature.
Meticulous essence of beauty.

Frame/Seating Finishes

Fabric: cotton - velour
elasticized fabric
fake fur
Leather: full grain ("pieno fiore") - nabuk
Special finishes

Legs Finishes

Brushed steel effect
Oxidized metal effect
Lacquered:
gloss - semi-gloss - flat
Wood: natural flat
gloss finish oak
bleached oak
Flat wenge effect
gloss - semi-gloss gold
Special finishes

Finitura Struttura/Seduta

Tessuto: cotone - velluto
tessuto elastico
pelliccia sintetica
Pelle: pieno fiore - nabuk
Finiture speciali

Finitura Piedini

Effetto acciaio satinato
Effetto metallo ossidato
Laccato:
lucido - semilucido - opaco
Legno: naturale opaco
rovere tinto lucido
rovere sbiancato
Effetto wengè opaco
lucido - oro semilucido
Finiture speciali

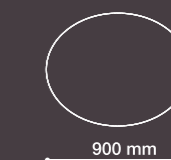

lovale poltroncina



VH15_018 | lovale poltroncina

Minimale e classica.
Un esercizio di stile tra passato e futuro.

Minimal and classic.
An exercise in style between past and future.

Frame/Seating Finishes

Fabric: cotton - velour
elasticized fabric
fake fur
Leather: full grain ("pieno fiore") - nabuk
Special finishes

Armrest/legs Finishes

Brushed steel effect
Oxidized metal effect
Lacquered:
gloss - semi-gloss - flat
Wood: natural flat
gloss finish oak
bleached oak
Flat wenge effect
gloss - semi-gloss gold
Special finishes

Finitura Struttura/Seduta

Tessuto: cotone - velluto
tessuto elastico
pelliccia sintetica
Pelle: pieno fiore - nabuk
Finiture speciali

Finitura Piedini/Braccioli

Effetto acciaio satinato
Effetto metallo ossidato
Laccato:
lucido - semilucido - opaco
Legno: naturale opaco
rovere tinto lucido
rovere sbiancato
Effetto wengè opaco
lucido - oro semilucido
Finiture speciali

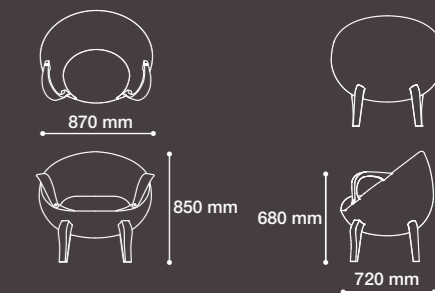

accantocomodino



VH15_020 | **accantocomodino**

L'oggetto diviene icona.
Il monogramma nell'interpretazione del comodino.

The object becomes icon.
The monogram in the interpretation of the night table.

Structure Finishes

Leather: full grain ("pieno fiore") - nabuk
Lacquered:
gloss - semi-gloss - flat
Wood: oak - walnut
wenge - ziricote - ebony
Special finishes

Finishes Insert H

Galvanic bath treatment:
shiny chrome - satin chrome
copper - brass

Glass top Finishes

Extra Light transparent
bronzed

Finitura Struttura

Pelle: pieno fiore - nabuk
Laccato:
lucido - semilucido - opaco
Legno: rovere - noce
wengè - ziricote - ebano
Finiture speciali

Finitura Inserto H

Bagno galvanico:
cromato lucido - satinato
ramato - ottonato

Piano in vetro

Extra Light trasparente
bronzato

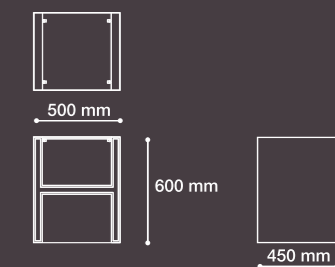

sella



VH14_001 | sella

Forma pura da pura intuizione

Materia essenziale, assoluta, curva e libera

Pure form from pure intuition

Matter that is essential, absolute, curved and free

Structure Finishes

Oxidised metal effect
Carbon effect
Varnished:
glossy - semi-glossy - matt
Fabric - jeans
Leather
Pony skin
Plexiglass
Wood: oak - walnut - wenge
Special finishes

Seat Finishes

Leather
Pony skin
Fabric: cotton - velvet
alcantara - jeans

Finitura Struttura

Effetto metallo ossidato
Effetto Carbonio
Laccato:
lucido - semilucido - opaco
Tessuto - Jeans
Pelle
Cavallino
Plexiglass
Legno: rovere - noce - wengé
Finiture speciali

Finitura Seduta

Pelle
Cavallino
Tessuto: cotone - velluto
alcantara - jeans

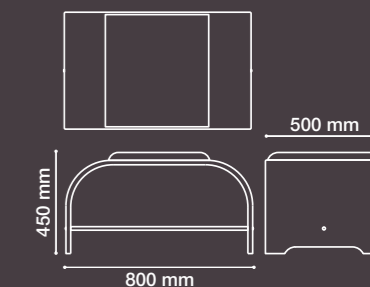

due+uno

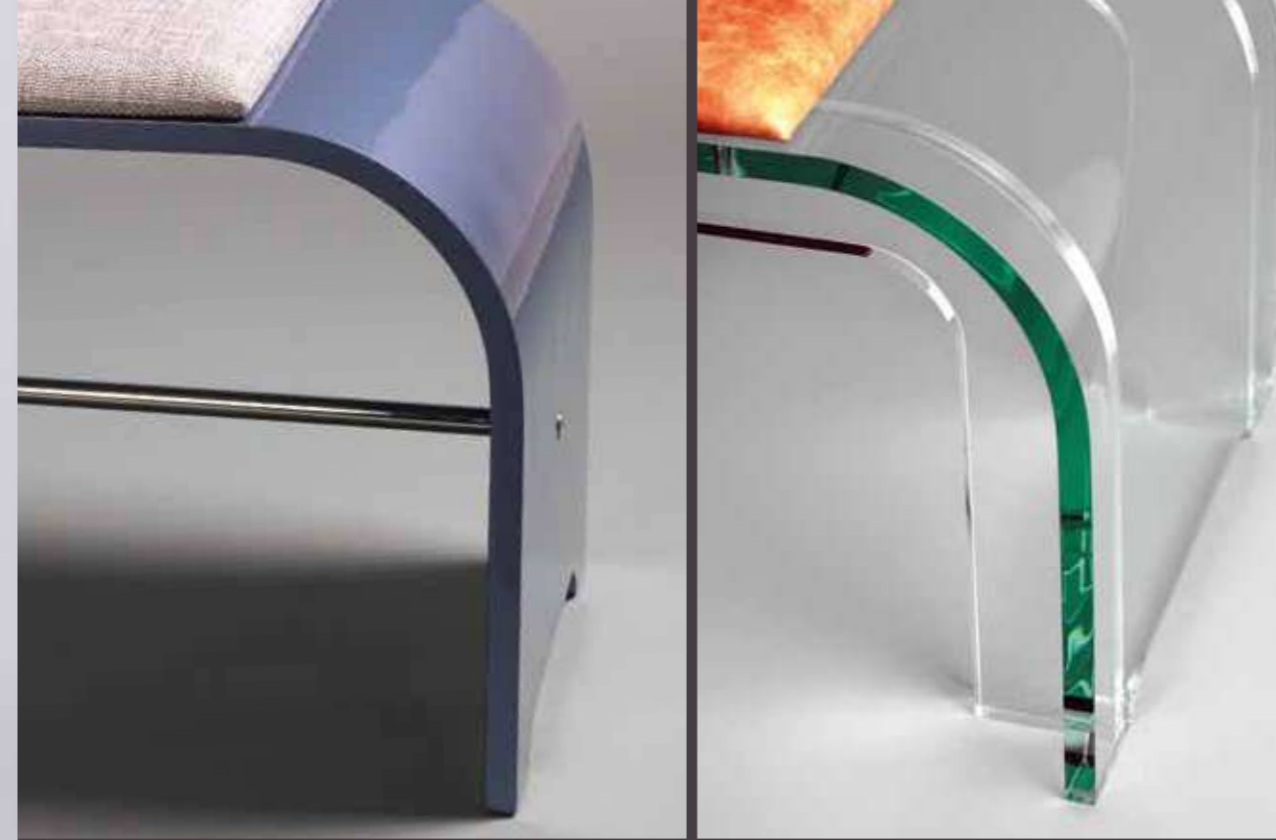

VH14_002 | due+uno

Leggerezza e forza.
Dialogo. Attesa. Complicità senza dubbio

Lightness and Strength.
Dialogue. Anticipation. Unquestionable complicity

Structure Finishes

Oxidised metal effect
Carbon effect
Varnished:
glossy - semi-glossy - matt
Fabric - jeans
Leather
Pony skin
Plexiglass
Wood: oak - walnut - wenge
Special finishes

Seat Finishes

Leather
Pony skin
Fabric: cotton - velvet
alcantara - jeans

Finitura Struttura

Effetto metallo ossidato
Effetto Carbonio
Laccato:
lucido - semilucido - opaco
Tessuto: Jeans
Pelle
Cavallino
Plexiglass
Legno: rovere - noce - wengé
Finiture speciali

Finitura Seduta

Pelle
Cavallino
Tessuto: cotone - velluto
alcantara - jeans

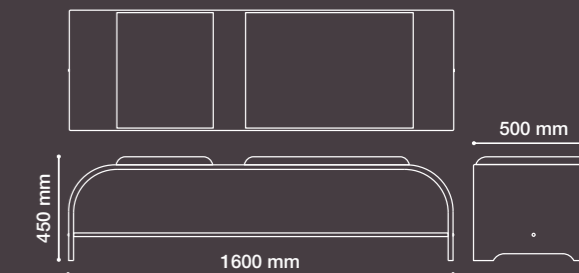

sinuosa

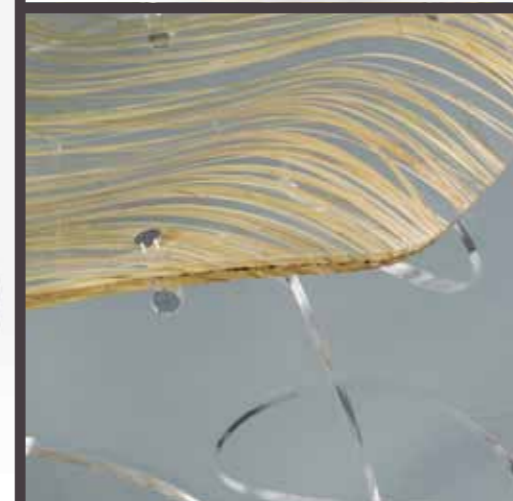

VH14_003 | sinuosa

Luce e materia avvolgono ed esaltano.
Sinuosa è esposta alla Triennale di Milano ed alla mostra
"La Magnifica Forma" di HOMI a Milano

Light and matter envelop and enhance.
Sinuosa is on display at the Triennale di Milano
and at the HOMI exhibition
"La Magnifica Forma" in Milan

Structure Finishes

Leather
Fabric: Cotton - Velvet
Alcantara - Jeans
Varnished:
glossy - semi-glossy - matt
Wood: oak - walnut - wenge

Base Finishes

Plexiglass
Varnished:
glossy - semi-glossy - matt
Wood: oak - walnut - wenge
Special finishes

Finitura Seduta

Pelle
Tessuto: Cotone - Velluto
Alcantara - Jeans
Laccato:
lucido - semilucido - opaco
Legno: rovere - noce - wengè

Finitura Basamento

plexiglass
Laccato:
lucido - semilucido - opaco
legno: rovere - noce - wengè
Finiture speciali

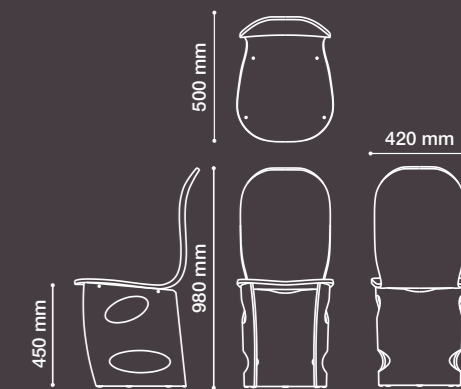

abbraccio



VH14_004 | abbraccio

Trasparente accoglienza.
Vuoti e pieni in essenziale equilibrio.

The transparency that envelops intimacy.
An essential balance between emptiness and fullness.

Structure Finishes

Plexiglass
Varnished:
glossy - semi glossy - matt
Wood: oak - walnut - wenge
zircote - Ebony - toulipier
Special effects

Seat Finishes

Plexiglass
Leather
Fabric: cotton - velvet
alcantara - jeans
Varnished:
glossy - semi glossy - matt
Wood: oak - walnut - wenge

Finitura Struttura

Plexiglass
Laccato:
lucido - semilucido - opaco
Legno: rovere - noce - wengè
zircote - ebano - toulipier
finiture speciali

Finitura Seduta

Plexiglass
Pelle
Tessuto: cotone - velluto
alcantara - jeans
Laccato:
lucido - semilucido - opaco
Legno: rovere - noce - wengè

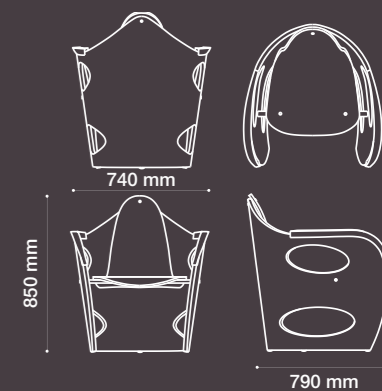

incontro



VH14_005 | incontro

Condividere lo spazio e il piacere.

Curve disegnate, smussano gli angoli, in uno spazio condiviso, la metafora dell'incontro.

Sharing space and pleasure.

Drawn curves, rounding off the corners, in a shared space, a metaphor for the encounter.

Structure Finishes

Oxidised metal effect
Varnished:
glossy - semi-glossy - matt
iWood: oak - walnut - wenge
Special finishes

Seat Finishes

Plexiglass
Leather
Fabric: cotton - velvet
alcantara - jeans
Wood: oak - walnut - wenge
Special finishes

Finitura Struttura

Effetto metallo ossidato
Laccato:
lucido - semilucido - opaco
Legno: rovere - noce - wengè
Finiture speciali

Finitura Seduta

Plexiglass
Pelle
Tessuto: cotone - velluto
alcantara - jeans
Legno: rovere - noce - wengè
Finiture speciali

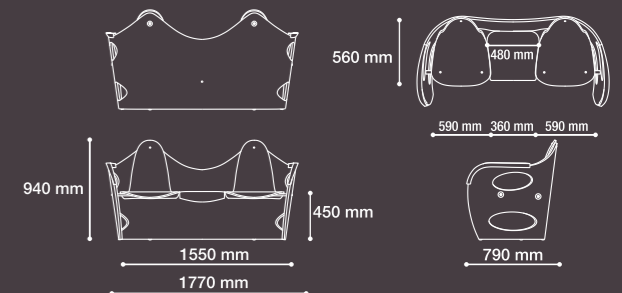

operachaiselongue

VH14_006 | opera

Incontro tra moderno e classico
nella reinterpretazione della chaise-longue.
L'eleganza come costante.

*Modern meets classic in this
interpretation of the chaise-longue.
Elegance as a constant.*

Structure Finishes

Oxidised metal effect
Carbon effect
Varnished:
glossy - semi-glossy - matt
Leather
Wood: oak - walnut - wengè
Special finishes

Seat Finishes

Leather
Pony skin
Fabric: cotton - velvet
alcantara - jeans

Finitura Struttura

Effetto metallo ossidato
Effetto carbonio
Laccato:
lucido - semilucido - opaco
Pelle
Legno: rovere - noce - wengè
Finiture speciali

Finitura Seduta

Pelle
Cavallino
Tessuto: cotone - velluto
alcantara - jeans

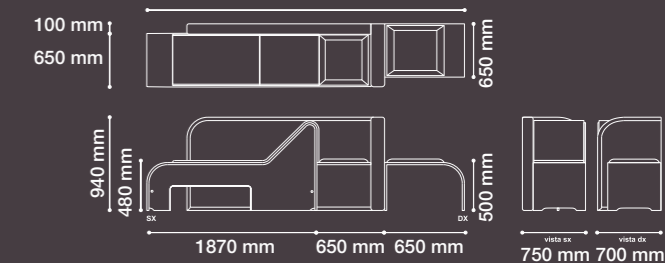

moai



VH14_007 | moai

Suggerzioni fuori dal tempo.
 Ingegno della mano. Il bello ed il comodo.
 Una scultura da vivere.

Suggestions out of time.
 Ingenuity of the hand. Beauty and comfort.
 A living sculpture.

Structure Finishes

Electroplating: Polished Chrome
 Satin - Copper - Brass
 Oxidised metal effect
 Varnished:
 glossy - semi-glossy
 matt - metallic - antique
 Treatment with takemakite®
 and cinnabar
 Special finishes

Finitura Struttura

Bagno Galvanico: cromato lucido
 satinato - ramato - ottonato
 Effetto metallo ossidato
 Laccato:
 lucido - semilucido - opaco
 metallizzato - anticato
 Trattamento con takemakite®
 e cinabro
 Finiture speciali

Seat Finishes

Leather
 Pony skin
 Fabric: cotton - velvet
 alcantara - jeans

Finitura Seduta

Pelle
 Cavallino
 Tessuto: cotone - velluto
 alcantara - jeans

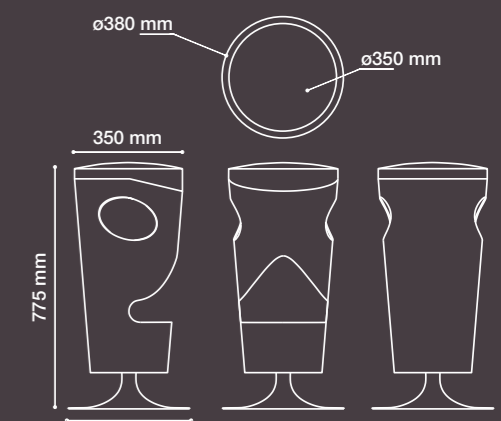

oblò



VH14_008 | oblò

Integrare le forme con le proprie emozioni.
Colmare la materia con le tracce d'individuali esperienze.

Integrating forms with emotions.
Bridging matter with traces of individual experiences.

Structure Finishes

Electroplating: polished chrome
satin - copper - brass
Oxidised metal effect
Varnished:
glossy - semi-glossy
matt - metallic - antique
Treatment with takemakite®
and cinnabar
Special finishes

Surface Finishes

Plexiglass

Finitura Struttura

Bagno Galvanico: cromato lucido
satinato - ramato - ottonato
Effetto metallo ossidato
Laccato:
lucido - semilucido - opaco
metallizzato - anticato
Trattamento con takemakite®
e cinabro
Finiture speciali

Finitura Piano

Plexiglass

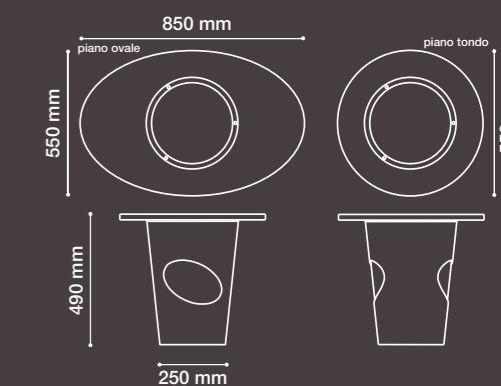

folio



VH14_009 | folio

Segni essenziali danno un senso allo spazio.
Supporti all'immaginazione. Concrete fantasie.

Essential signs offer a sense of space.
Supporting the imagination. Bringing fantasies to life.

Structure Finishes

Oxidised metal effect
Carbon effect
Varnished:
glossy - semi-glossy - matt
Leather
Wood: oak - walnut - wenge
Special finishes

Finitura Struttura

Effetto metallo ossidato
Effetto carbonio
Laccato:
lucido - semilucido - opaco
Pelle
Legno: rovere - noce - wengè
Finiture speciali

Leg and Magazine holder Finishes

Plexiglass

Finitura Gambe e Portariviste

Plexiglass

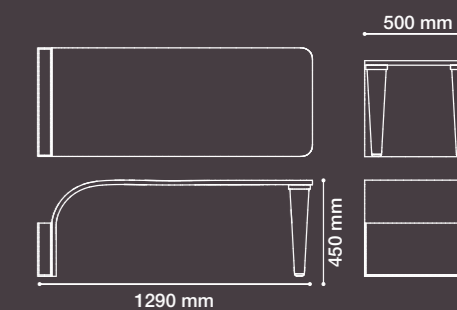

spaziomio

VH14_010 | spaziomio

Modificare la visione.

Mettere al centro l'Uomo.
Tradurre l'eccellenza in materia e metterla al Suo servizio.

Modifying the vision.

Putting people first.
Translating excellence into matter at the service of humankind.

Table Structure

Electroplating: polished chrome
satin - copper - brass
Oxidised metal effect
Varnished: glossy - semi-glossy
matt - metallic - antique
Treatment with takemakite®
and cinnabar
Special finishes

Struttura Tavolo

Bagno Galvanico: cromato lucido
satinato - ramato - ottonato
Effetto metallo ossidato
Laccato: lucido - semilucido - opaco
metallizzato - anticato
Trattamento con takemakite®
e cinabro
Finiture speciali

Side Container

Oxidised metal effect
Varnished: glossy - semi glossy - matt
Leather
Wood: oak - walnut - wenge
Special finishes

Contenitori Laterali

Effetto metallo ossidato
Laccato: lucido - semilucido - opaco
Pelle
Legno: rovere - noce - wengè
Finiture speciali

Glass shelves and vertical inserts

Extra light transparent
Layered coloured

Spalle e ripiani in vetro

Extra light trasparente
Stratificato colorato

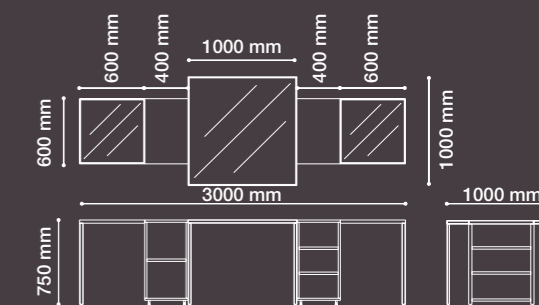

spicchio

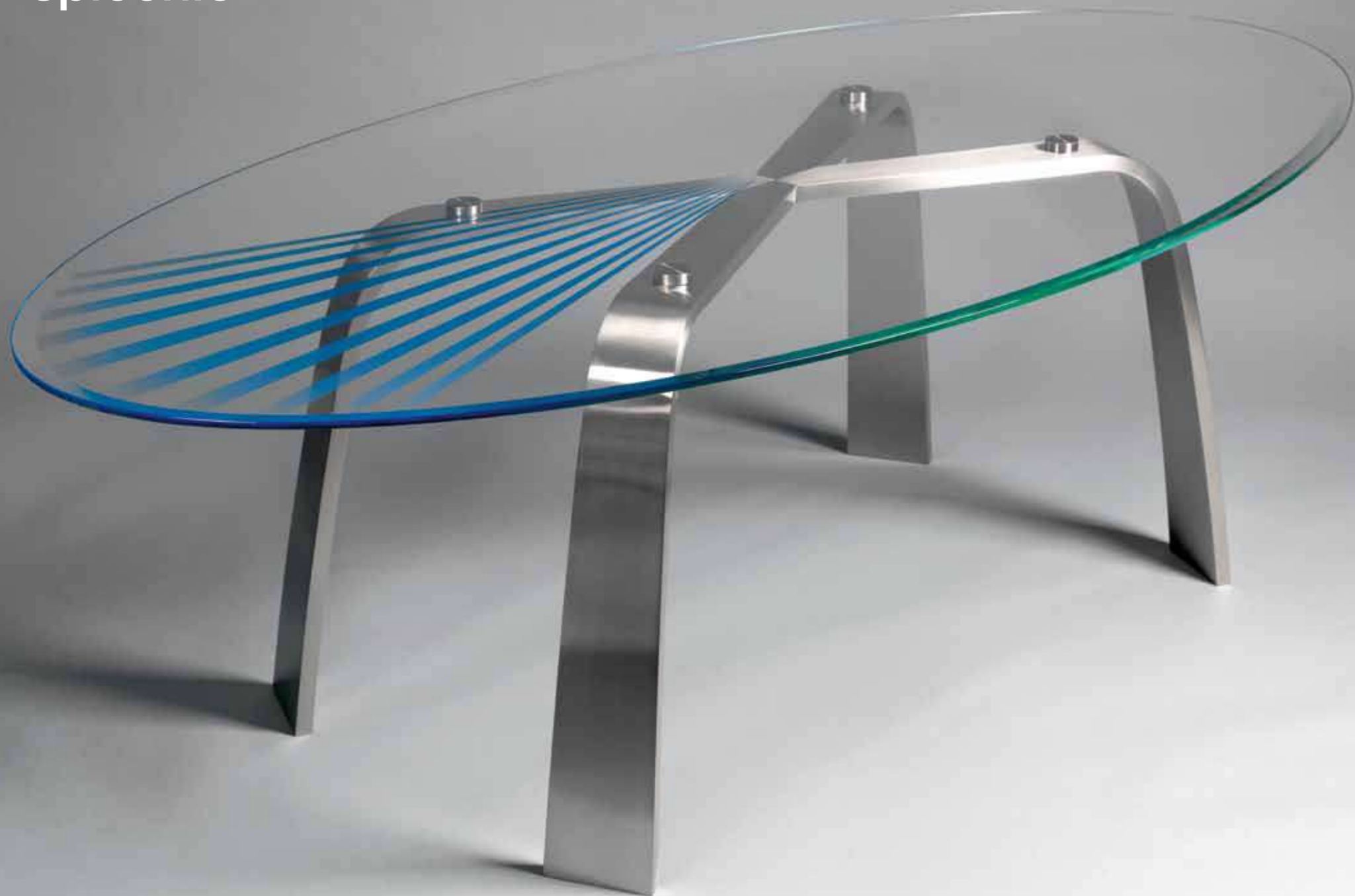

VH14_011 | spicchio

Acciaio e vetro. Libertà dalle mode.

Libertà dai limiti delle forme.
Libertà di dare alle superfici un senso. Personale.

Steel and glass. Freedom from fashion.

Freedom from the limitations of form.
Freedom to give the surface a sense. Personal.

Base table

Electroplating: polished chrome
satin - copper - brass
Oxidised metal effect
Varnished: glossy - semi-glossy
matt - metallic - antique
Treatment with takemakite®
and cinnabar
Special finishes

Basamento tavolo

Bagno Galvanico: cromato lucido
satinato - ramato - ottonato
Effetto metallo ossidato
Laccato: lucido - semilucido
opaco - metallizzato - anticato
Trattamento con takemakite®
e cinabro
Finiture speciali

Glass surface

Extra light transparent
"Segment" section customisable

Piano in vetro

Extra Light Trasparente
Sezione a "spicchio" personalizzabile

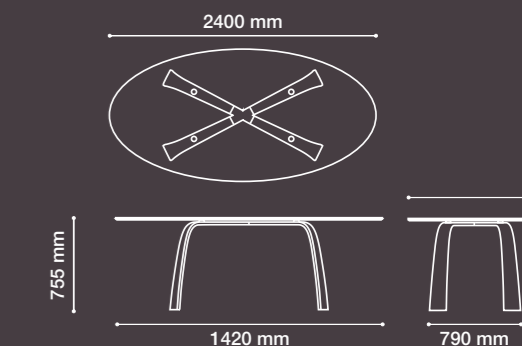

spaziotempo

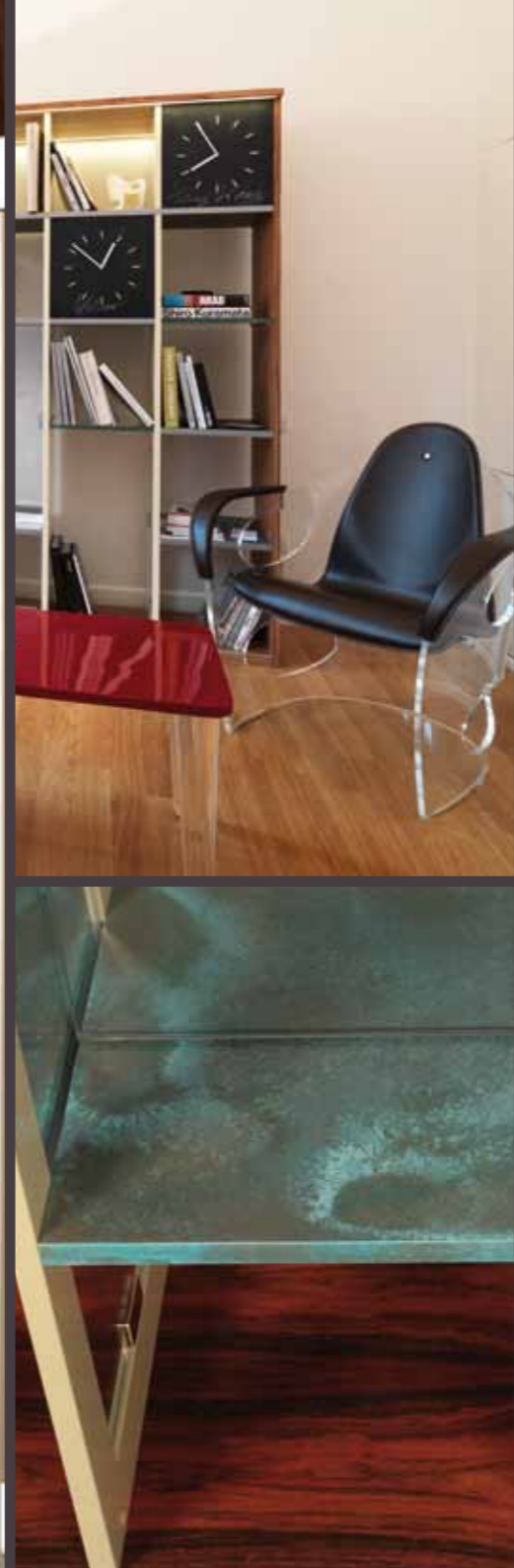

VH14_012 | spaziotempo

Separare gli spazi.
Unire nella luce il tempo e la materia.

Separating spaces.
Uniting time and matter in the light.

Structure Finishes

Oxidised metal effect
Varnished: glossy - semi-glossy - matt
Leather
Wood: oak - walnut - wenge
Special finishes

Glass Finishes

VERTICAL INSERTS AND SHELVES
Extra Light Transparent
Layered Coloured
Printed

Doors and Clock

Blackboard effect

LED

RGB - White
Devices equipped with remote control

Finitura Struttura

Effetto metallo ossidato
Laccato: lucido - semilucido - opaco
Pelle
Legno: rovere - noce - wengè
Finiture speciali

Finitura in vetro

INSERTI VERTICALI E RIPIANI
Extra light trasparente
Stratificato colora
Stampato

Ante e Orologio

Effetto lavagna

LED

RGB - Bianco
Dispositivi dotati di telecomando

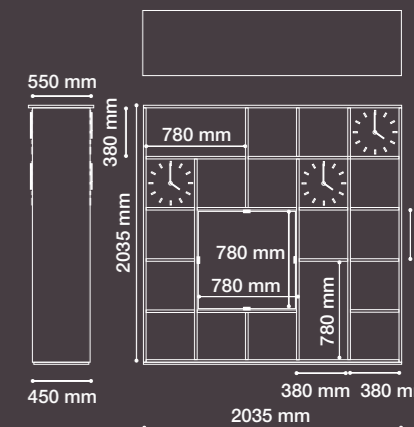

elica



VH14_013 | elicatavolo

La ricerca del bello:
un vortice di potente eleganza.

The search for beauty:
a vortex of powerful elegance.

Table Base

Electroplating: polished chrome
satin - copper - brass
Oxidised metal effect
Varnished: glossy - semi-glossy - matt
metallic - antique
Treatment with takemakite[®] and cinnabar
Special finishes

Surface

Oxidised metal effect
Varnished: glossy - semi-glossy - matt
metallic - antique
Wood: oak - walnut - wengè
Special finishes

Helicoidal inserts in the surface

Electroplating: polished chrome
satin - copper - brass
Oxidised metal effect
Varnished: glossy - semi-glossy
matt - metallic - antique
Treatment with takemakite[®] and cinnabar
Plexiglass
Special finishes

Inserts glass surface

Extra light transparent

Basamento tavolo

Bagno galvanico: cromato lucido
satinato - ramato - ottonato
Effetto metallo ossidato
Laccato: lucido - semilucido - opaco
metallizzato - anticato
Trattamento con takemakite[®] e cinabro
Finiture speciali

Piano

Effetto metallo ossidato
Laccato: lucido - semilucido - opaco
metallizzato - anticato
Legno: rovere - noce - wengè
Finiture speciali

Inserti elicoidali nel piano

Bagno Galvanico: cromato lucido
satinato - ramato - ottonato
Effetto metallo ossidato
Laccato: lucido - semilucido - opaco
metallizzato - anticato
Trattamento con takemakite[®] e cinabro
Plexiglass
Finiture speciali

Inserto piano in vetro

Extra light trasparente



740 mm



1200 mm

HODARA[®]

ART DESIGNER

HODARA S.R.L.

VIA G. MORONE 8 - 20121 MILANO (ITALY)

TEL. +39 02 7634 1375

FAX +39 02 7601 4482

info@hodaradesigner.com

hodaradesigner.com

Accessories: Nella Longari Home - Bougeotte

Photo: Davide Bodini - Anna Minaeva

A.D. Claudio D'Onofrio - Blucannella

Stampa: Tecnografica S.r.l.